

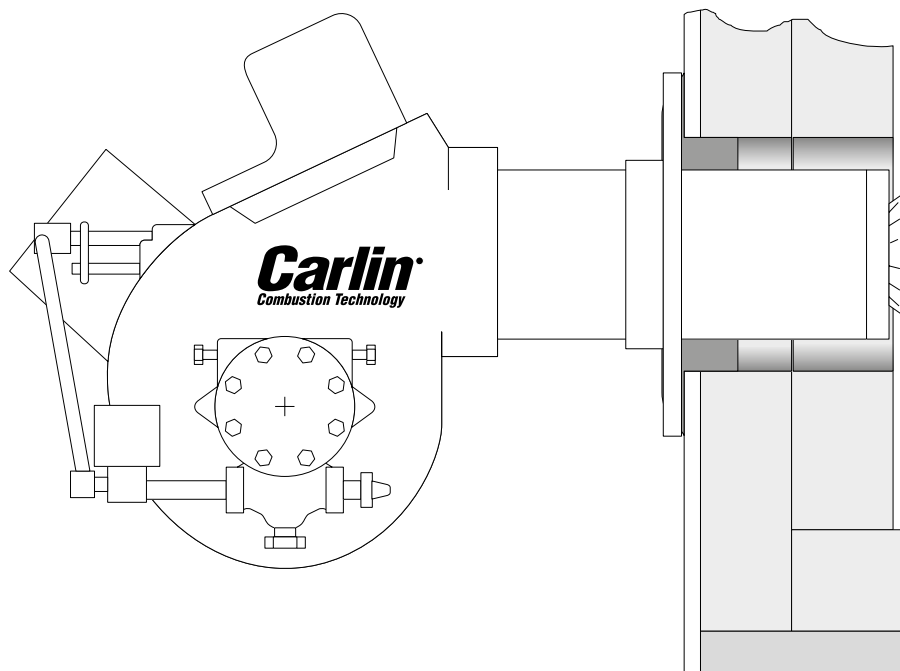

VISION™ EVAPORATOR



GUIDE TO CONVERTING YOUR VISION™ EVAPORATOR TO OIL
SIMPLIFIED CARLIN BURNER OPERATION GUIDE

June 2026 | Version 01



IMPORTANT | USE THIS GUIDE TO CONVERTING YOUR VISION™ Evaporator TO OIL if you are doing the conversion USING CARLIN BURNER model 102CRD, 301CRD, or 601CRD.



IMPORTANT - CARLIN BURNER MANUAL | KEEP THE CARLIN BURNER USER MANUAL PROVIDED TO YOU BY THE MANUFACTURER*. You will need to consult it to understand how the burner works.

** This manual is provided to you with your Carlin burner.*

INFORMATION AND LITERATURE REGARDING CARLIN PRODUCTS

The documents below are available on the website of the manufacturer Carlin.



carlincombustion.com



Carlin 102CRD burner

[Product page](#)

[User manual for the product](#)



Carlin 301CRD burner

[Product page](#)

[User manual for the product](#)



Carlin 601CRD burner

[Product page](#)

[User manual for the product](#)



Carlin 40200 controller

[Product page](#)

[User manual for the product](#)

This manual is also available in Appendix A of this manual.

INFORMATION ABOUT THE MANUFACTURER

Carlin Combustion Technology

North Haven, CT

Email | info@carlincombustion.com

Customer service | 203-680-9401

Technical service | 800-989-2275

VISION™ EVAPORATOR



TABLE OF CONTENTS

Information and literature regarding Carlin products and the manufacturer	C2
PART 1: GUIDE TO CONVERTING YOUR VISION™ EVAPORATOR TO OIL	3
SECTIONS	
1. Required components for converting your VISION™ evaporator to oil	4
2. Steps for converting your VISION™ evaporator to oil.....	8
2.1 Modifying the door.....	8
2.1.1 Removing the door closing plate.....	8
2.1.2 Installing the additional hinges for the door.....	8
2.1.3 Removing the handle, shaft, and guide plate	10
2.1.4 Installing the door retaining plates	10
2.1.5 Aligning the mounting holes of the plates and hinges.....	11
2.1.5.1 Difficulty aligning the mounting holes between the plates and the additional hinges.....	12
2.2 Installing the burner	13
2.2.1 Removing the ceramic glass from the door	13
2.2.2 Installing the burner mounting plate in the door	14
2.2.3 Installing the flange and the sealing gasket on the mounting plate.....	14
2.2.4 Installing the burner barrel in the mounting plate and the flange	15
2.2.5 Installing the burner in the barrel	17
2.3 Modifying the combustion chamber and the thermal protection	18
2.3.1 Installing the riser plate and the insulating wool	19
2.4 Electricity and fuel oil connection of the burner	20
PART 2: SIMPLIFIED CARLIN BURNER OPERATION GUIDE.....	21
SECTIONS	
1. Burner operation	22
1.1 First lifetime startup of the burner.....	22
1.2 Burner operation sequence	22
2. Maintenance.....	24
2.1 Burner startup at the beginning of each season	24
2.2 Burner shutdown at the end of each season.....	24
2.3 Three-year maintenance: nozzle, burner, and carbon monoxide	24
3. Parts and consumables.....	25

4. Troubleshooting kit	26
4.1 The burner does not ignite following the pre-purge cycle	26
4.2 The red LED indicator light illuminates: ERROR / Reset	26
4.3 The yellow and red LED indicator lights illuminate simultaneously: ERROR / Technician	26

TABLE OF ILLUSTRATIONS

ILLUSTRATION 1 Removing the door closing plate	8
ILLUSTRATION 2 Additional hinges for the 24-inch VISION™ door	9
ILLUSTRATION 3 Additional hinges for the 30- and 36-inch VISION™ door	9
ILLUSTRATION 4 Handle, shaft, and guide plate	10
ILLUSTRATION 5 Door retaining plates	11
ILLUSTRATION 6 Aligning the mounting holes of the plates and hinges.	12
ILLUSTRATION 7 Removing the ceramic glass from the door	13
ILLUSTRATION 8 Installing the burner mounting plate in the door.	14
ILLUSTRATION 9 Installing the flange and the seal in the mounting plate	15
ILLUSTRATION 10 Removing the barrel from the burner.	16
ILLUSTRATION 11 Installing the barrel in the door/mounting plate.	16
ILLUSTRATION 12 Installing the burner in the barrel.	18
ILLUSTRATION 13 Installing the riser plate and the insulating wool	19
ILLUSTRATION 14 Carlin burner controller model 40200	23

TABLE OF TABLES

TABLE 1 24-inch VISION™ conversion kit parts	5
TABLE 2 30- and 36-inch VISION™ conversion kit parts	6
TABLE 3 Carlin burner required according to your VISION™ evaporator model.	7
TABLE 4 Identification of the Lapierre conversion kit code, the Carlin burner, and the nozzle for each VISION™ evaporator model	7
TABLE 5 Electrical specifications	20
TABLE 6 Carlin burner statuses and LED indicator lights.	23

APPENDIX

APPENDIX A User manual for Carlin controller model 40200	27
--	----

TABLE OF WARNINGS

Use this guide to converting your VISION™ to oil using Carlin burner	C2
Keep the Carlin burner user manual provided to you by the manufacturer	C2
Wear a dust mask and gloves when installing the insulating wool	19
The presence of black smoke or soot under the pans requires the assistance of a qualified technician.	22-24
LAPIERRE EQUIPMENT assumes no liability for the content of the user manual for the Carlin controller.	27

PART 1

GUIDE TO
**CONVERTING YOUR VISION™
EVAPORATOR TO OIL**



SECTION 1 REQUIRED COMPONENTS FOR CONVERTING YOUR VISION™ EVAPORATOR TO OIL

IMPORTANT | The conversion of your VISION™ evaporator to oil must be CARRIED OUT WHEN THE PANS ARE NOT INSTALLED ON THE EVAPORATOR.

Find below the required components for converting your VISION™ evaporator to oil. Ensure that you have all the components before starting the conversion operation.

WHAT YOU NEED | To convert your VISION™ evaporator to an oil-powered evaporator, you will need:

- the components listed below, which vary according to your VISION™ evaporator model:
 - the conversion kit parts (*Tables 1, 2, and 4*),
 - the Carlin burner (*Tables 3 and 4*),
 - the nozzle (*Table 4*),
- the following components, not provided, available at your hardware store,
 - an electrical plug (*Section 2.4*),
 - a power cord (*Section 2.4*),
 - an electrical power switch (*Section 2.4*),
- the following tools:
 - a set of wrenches or ratcheting socket wrenches for the various nuts and bolts,
 - a flat screwdriver (*Section 2.2.4*),
 - a crescent wrench and a level (*Section 2.2.5*),
 - o for the 301CRD and 601CRD burners only,
- an electrical contractor (*Section 2.4*),
- a contractor specializing in oil-powered burner systems (*Section 2.4*).

- A Lapierre Equipment technician (*PART 2 - Section 1.1*).

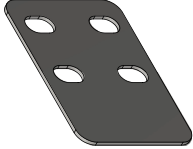
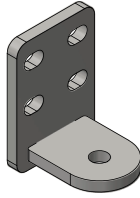
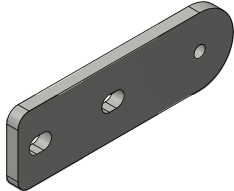
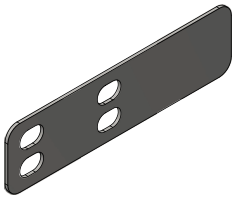
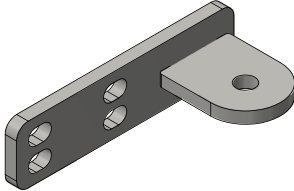
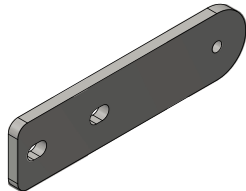
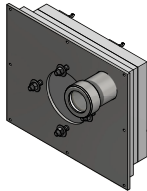
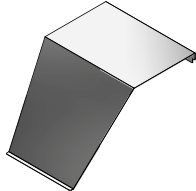
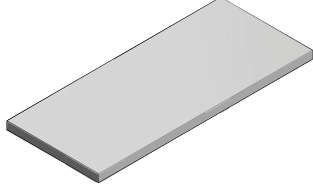

SECTION 1 Required components for converting your VISION™ evaporator to oil (continued)

TABLE 1 | 24-inch VISION™ conversion kit parts

 <p>(A) Blocking for upper additional hinge Quantity: 2</p>	 <p>(B) Upper additional hinge Quantity: 1</p>	 <p>(E) Upper door retaining plate Quantity: 1</p>
 <p>(C) Blocking for lower additional hinge Quantity: 2</p>	 <p>(D) Lower additional hinge Quantity: 1</p>	 <p>(F) Lower door retaining plate Quantity: 1 NOTE This component is slightly longer than component “E”.</p>
 <p>(G) Carlin burner mounting plate Quantity: 1</p>	 <p>(H) Riser plate Quantity: 1</p>	 <p>(I) Insulating wool 2 in (5.08 cm) thick Quantity: 1</p>
<p>(J) Eight identical bolts and washers to attach the additional hinges (B and D) to the front chassis of the VISION™.</p> <ul style="list-style-type: none"> • 5/16 in -18 x 1 in bolt, matching slotted locking and flat washers. 		
<p>(K) Two identical bolts, washers, and nuts to join the retaining plates (E and F) to the hinges (B and D).</p> <ul style="list-style-type: none"> • 5/16 in -18 x 1 in bolt, matching slotted locking and flat washers and nut. 		

SECTION 1 Required components for converting your VISION™ evaporator to oil (continued)

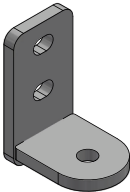
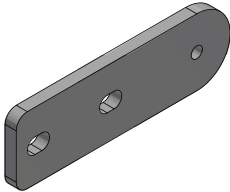
TABLE 2 | 30- and 36-inch VISION™ conversion kit parts

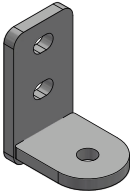
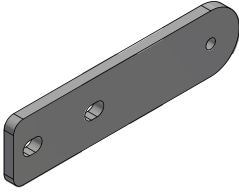
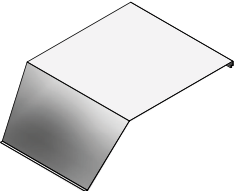
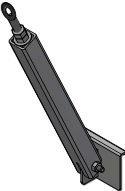
 <p>(L) Blocking for upper additional hinge Quantity: 2</p>	 <p>(M) Upper additional hinge Quantity: 1</p>	 <p>(P) Upper door retaining plate Quantity: 1</p>
 <p>(N) Blocking for lower additional hinge Quantity: 2</p>	 <p>(O) Lower additional hinge Quantity: 1</p>	 <p>(Q) Lower door retaining plate Quantity: 1 NOTE This component is slightly longer than component “P”.</p>
 <p>(R) Carlin burner mounting plate Quantity: 1</p>	 <p>(S) Riser plate Quantity: 1</p>	 <p>(T) Insulating wool 1 in (2.54 cm) thick 30-inch Quantity: 3 36-inch Quantity: 3</p>
 <p>(U) Burner support rod • Including one bolt and one washer for the eyelet. Quantity: 1</p>	<p>(V) Four identical bolts and washers to attach the additional hinges (M and O) to the front chassis of the VISION™. • 5/16 in -18 x 1 in bolt, matching slotted locking and flat washers.</p> <p>(W) Two identical bolts, washers, and nuts to join the retaining plates (P and Q) to the hinges (M and O). • 5/16 in -18 x 1 in bolt, matching slotted locking and flat washers and nut.</p>	

NOTE | The sizes of some parts in your kit may be considerably different from those presented in this table.

SECTION 1 Required components for converting your VISION™ evaporator to oil (continued)

TABLE 3 | Carlin burner required according to your VISION™ evaporator model



 <p>For 24 x 72 in 24 x 96 in VISION™ models</p>	 <p>For 24 x 120 in 30 x 120 in VISION™ models</p>	 <p>For 36 x 120 in 36 x 144 in VISION™ models</p>
<p style="text-align: center;">Parts provided with the Carlin burner</p> <p style="text-align: center;">A flange (<i>Illustration 9, No. 1</i>), a sealing gasket (<i>Illustration 9, No. 2</i>), and a user manual for the burner.</p> <p style="text-align: center;">The controller (1) is previously assembled on the burner.</p> <p style="text-align: center;">The controller (1) model shown above may differ from the one installed on your burner. <i>You can find the user manual for the Carlin controller in Appendix A.</i></p>		

TABLE 4 | Identification of the Lapierre conversion kit code, the Carlin burner, and the nozzle for each VISION™ evaporator model

VISION™ evaporator model	Lapierre conversion kit code*	Carlin burner (Table 3)	Nozzle** (USG/hr)
24 x 72 in (2 x 6 ft)	OP017-247200XX	102CRD	3.5
24 x 96 in (2 x 8 ft)	OP017-249600XX	102CRD	4
24 x 120 in (2 x 10 ft)	OP017-241000XX	301CRD	5
30 x 120 in (2-1/2 x 10 ft)	OP017-301000XX	301CRD	6.5
36 x 120 in (3 x 10 ft)	OP017-361000XX	601CRD	8
36 x 144 in (3 x 12 ft)	OP017-361200XX	601CRD	9

*The conversion kit includes the components shown in *Table 1* for the 24-inch evaporators, and those shown in *Table 2* for the 30- and 36-inch evaporators.

**The nozzle is a separate component of the burner and must be ordered separately. It is recommended to have a spare nozzle on hand. Nozzles are available from your *LAPIERRE EQUIPMENT* distributor.

SECTION 2 STEPS FOR CONVERTING YOUR VISION™ EVAPORATOR TO OIL

The information allowing you to convert your VISION™ evaporator to oil in four steps can be found below.

- 2.1 Modifying the door
- 2.2 Installing the burner
- 2.3 Modifying the combustion chamber and the thermal protection
- 2.4 Electricity and fuel oil connection for the burner

2.1 MODIFYING THE DOOR

2.1.1 Removing the door closing plate

- Have a tool for unscrewing and screwing the bolts on hand.
- Open the door.
- Unscrew and set aside the two bolts and the washers (1) from the closing plate (2).
 - ✗ Keep and put away the plate, since it will no longer be used.
- Tighten the two bolts and washers firmly but not excessively into the same places.

ILLUSTRATION 1 | Removing the door closing plate

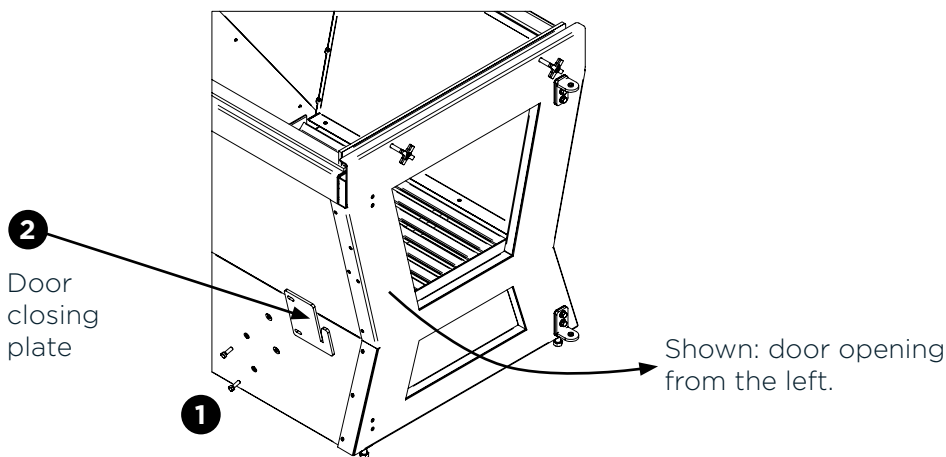

2.1.2 Installing the additional hinges for the door

- Depending on whether you have a 24-, 30-, or 36-inch model, gather the following parts from the conversion kit from *Table 1* or *Table 2*.
 - **Table 1: 24-inch** | A and B, C and D, and the eight identical bolts and washers (J) to attach the additional hinges to the front chassis of the VISION™.
 - **Table 2: 30- and 36-inch** | L and M, N and O, and the four identical bolts and washers (V) to attach the additional hinges to the front chassis of the VISION™.
- Have a tool for screwing the bolts on hand.
- Install the additional hinges on the front chassis of the VISION™, on the opposite side of the existing hinges. To do so, attach the blocking and the hinges using the identical bolts and washers.
 - Make sure to place the 2 blocking strips properly under the hinges, as shown below.
 - Tighten the bolts firmly but not excessively.

SECTION 2 Steps for converting your VISION™ evaporator to oil (continued)

ILLUSTRATION 2 | Additional hinges for the 24-inch VISION™ door

NOTE | The letters in brackets refer to *Table 1*.

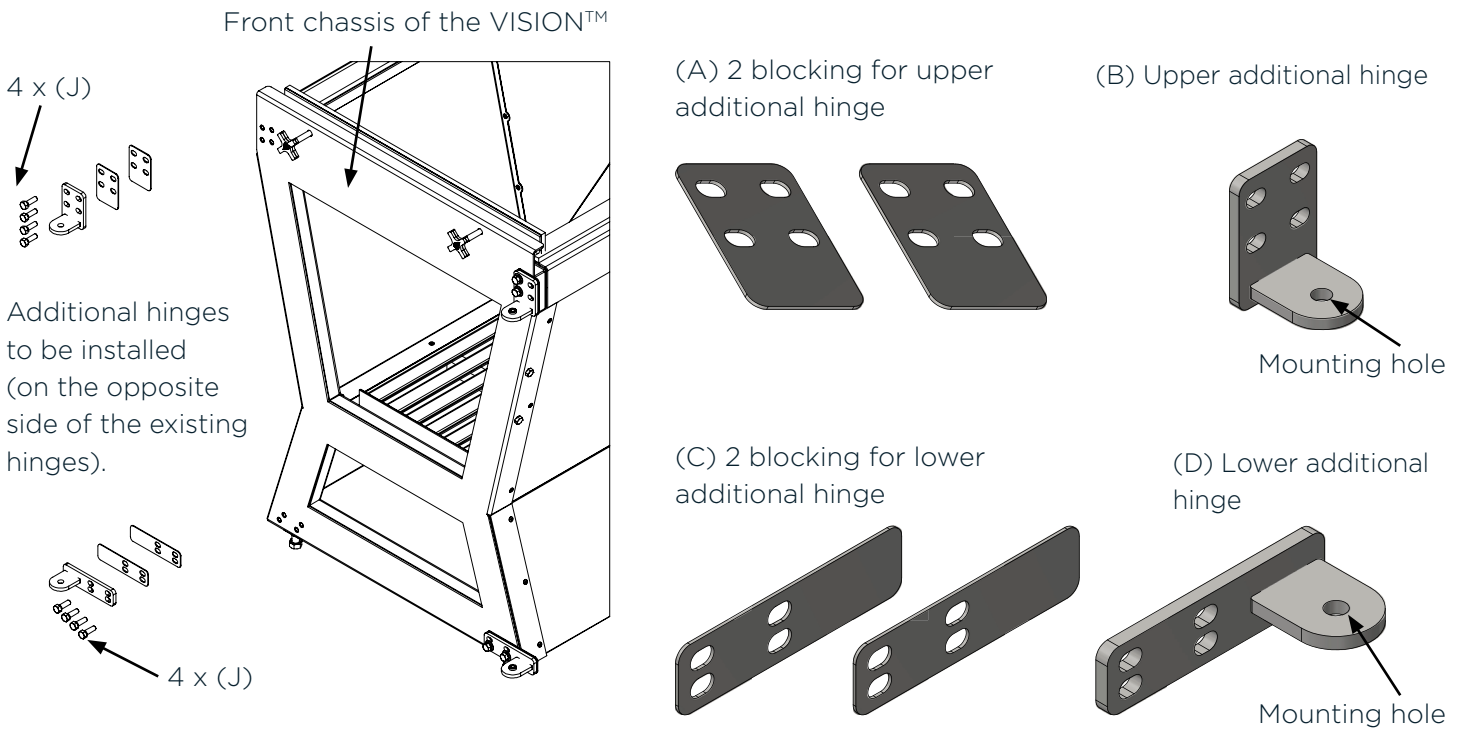
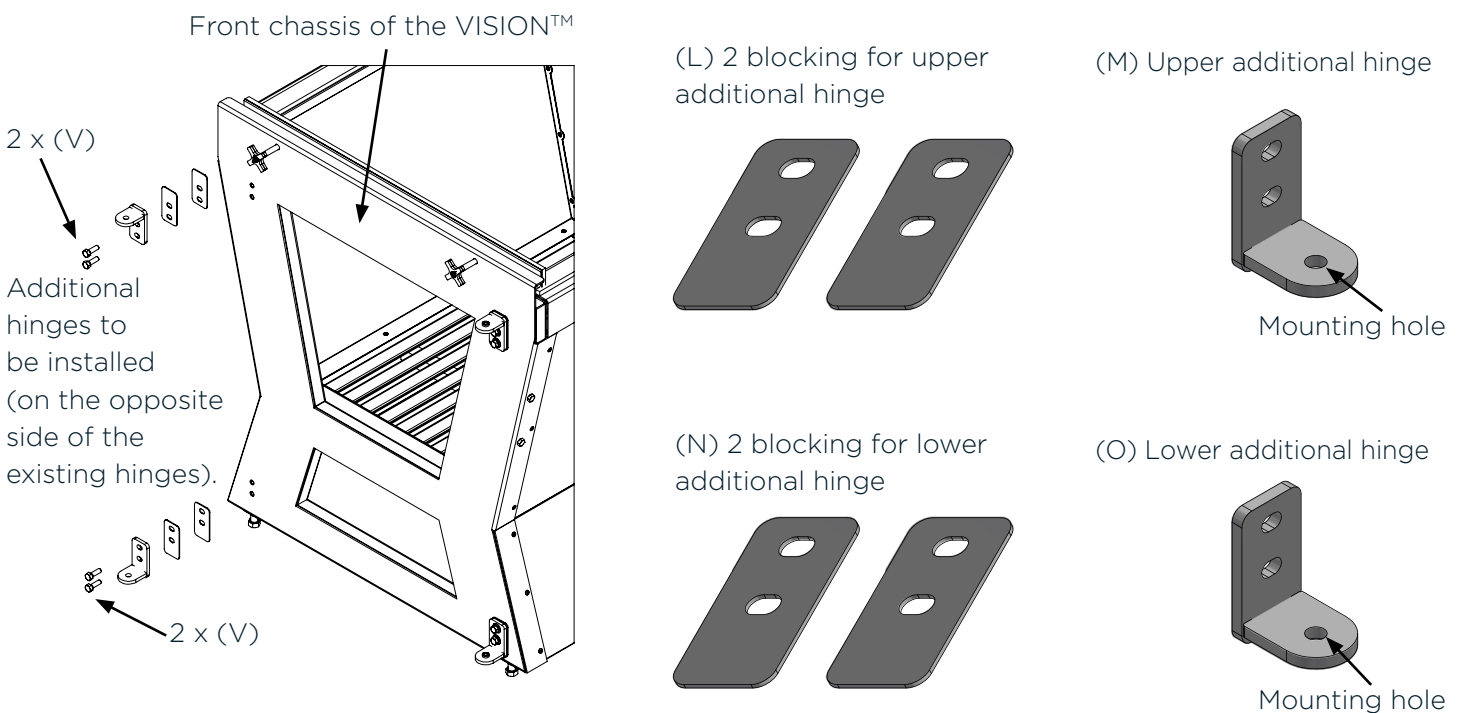

ILLUSTRATION 3 | Additional hinges for the 30- and 36-inch VISION™ door

NOTE | The letters in brackets refer to *Table 2*.



SECTION 2 Steps for converting your VISION™ evaporator to oil (continued)

2.1.3 Removing the handle, shaft, and guide plate

- Have a tool for unscrewing and screwing the bolts on hand.
- Unscrew and set aside the bolt and the washers (1) from the handle shaft (4).
 - ✘ Keep and put away the door handle and shaft, since they will no longer be used.
 - Screw the bolt and the washers firmly but not excessively into the same place.
- Unscrew and set aside the two bolts and the washers (2) from the guide plate (3).
 - ✘ Keep and put away the plate, since it will no longer be used.
 - Screw the two bolts and the washers from the plate firmly but not excessively into the same places.

ILLUSTRATION 4 | Handle, shaft, and guide plate

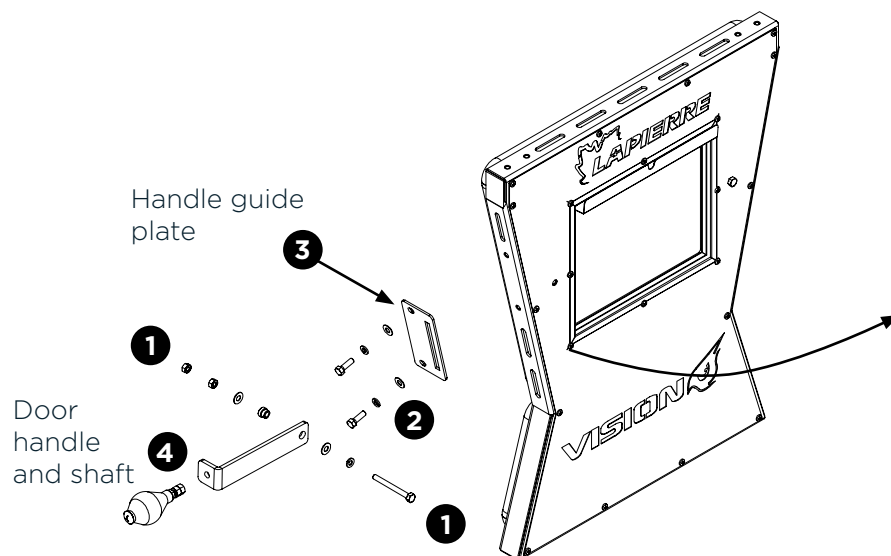

2.1.4 Installing the door retaining plates

- Retrieve the two door retaining plates from the conversion kit [E and F (24 in) | P and Q (30 and 36 in)].
- Have a tool for unscrewing and screwing the bolts on hand.
- Unscrew and set aside the two bolts and the washers (1) located on the opposite side of the existing upper hinge on your door.
 - Although they are not currently in use, these bolts and washers are already attached to your door.
- Repeat the previous instruction for the existing lower hinge.
- Use these four bolts and washers to install the two retaining plates on the door as shown in *Illustration 5, No. 2*. The shorter plate (E or P) must be attached to the top of the door, and the longer plate (F or Q) to the bottom.
- Tighten the bolts enough so that they stay in place, but not all the way. This makes it easier to align the mounting holes (3) of the retaining plates with those of the additional hinges that you installed on the front chassis of the VISION™ in *Section 2.1.2*.

ILLUSTRATION 5 | Door retaining plates

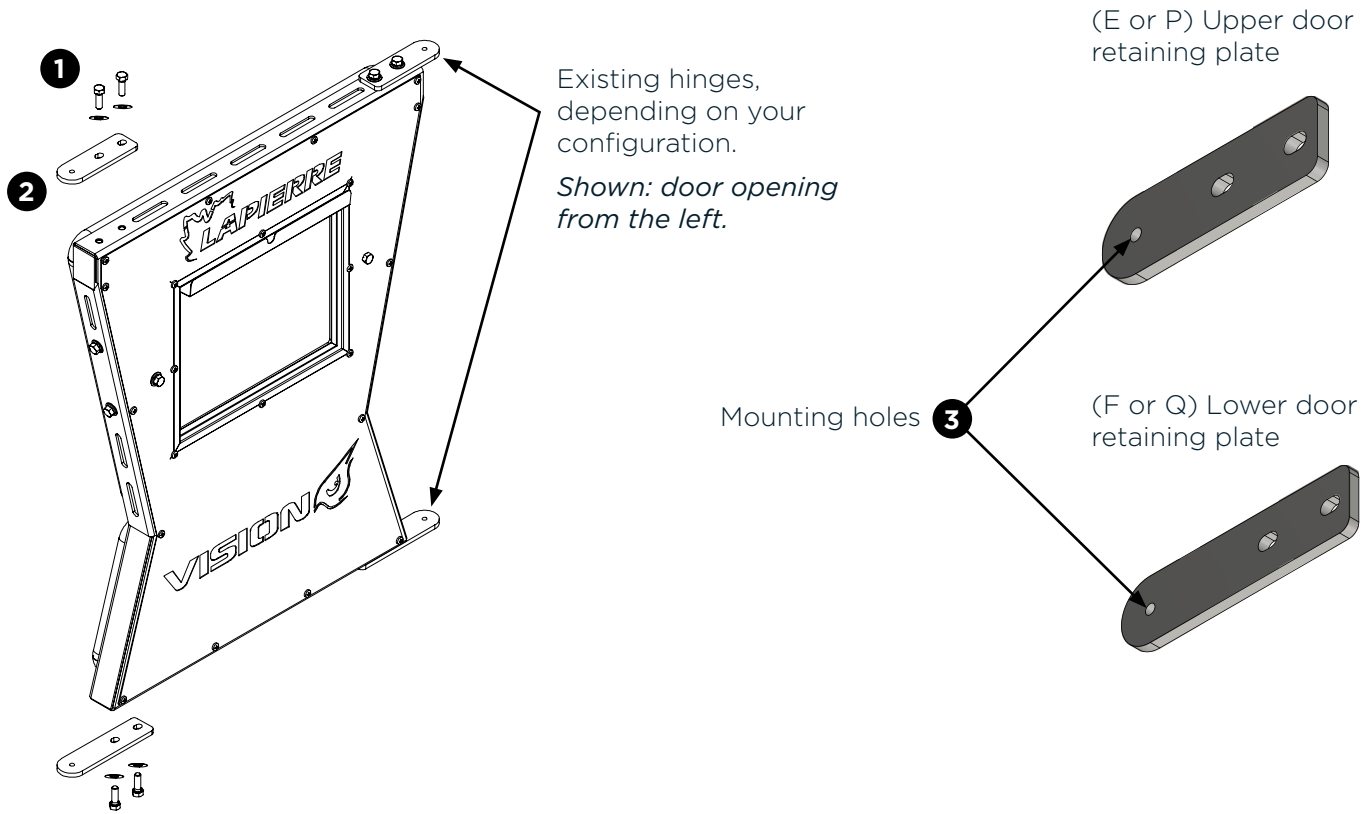

2.1.5 Aligning the mounting holes of the plates and hinges

- Retrieve the two identical bolts, washers, and nuts (K or W) allowing the retaining plates to be mounted on the hinges.
- Have the tools for screwing the bolts and nuts on hand.
- Close the door.
- The upper retaining plate (1) must rest on the upper additional HINGE (2).
 - It must come over the hinge, not underneath it.
 - The instruction is the same for the lower additional hinge.
- Proceed with the alignment of the mounting hole (*Illustration 5, No. 3*) of the upper plate with that of the hinge.
 - Use one of the bolts (K or W) (3), if necessary, to facilitate the alignment.
 - Put the bolt in place in the mounting hole in order to mount the plate and the hinge.

NOTE | If you encounter difficulties aligning the mounting holes, refer to *Section 2.1.5.1*.

- Repeat the previous instruction for the lower plate and the hinge.
- Once the bolts (K or W) are freely inserted into the mounting holes between the plates and the additional hinges, tighten the four bolts of the TWO DOOR RETAINING PLATES (1) firmly but not excessively.
- Then, tighten the two bolts and their washers using their nut (K or W) (3) firmly but not excessively to mount the plates on the hinges.

Following this step, the modification of the door is complete.

ILLUSTRATION 6 | Aligning the mounting holes of the plates and hinges

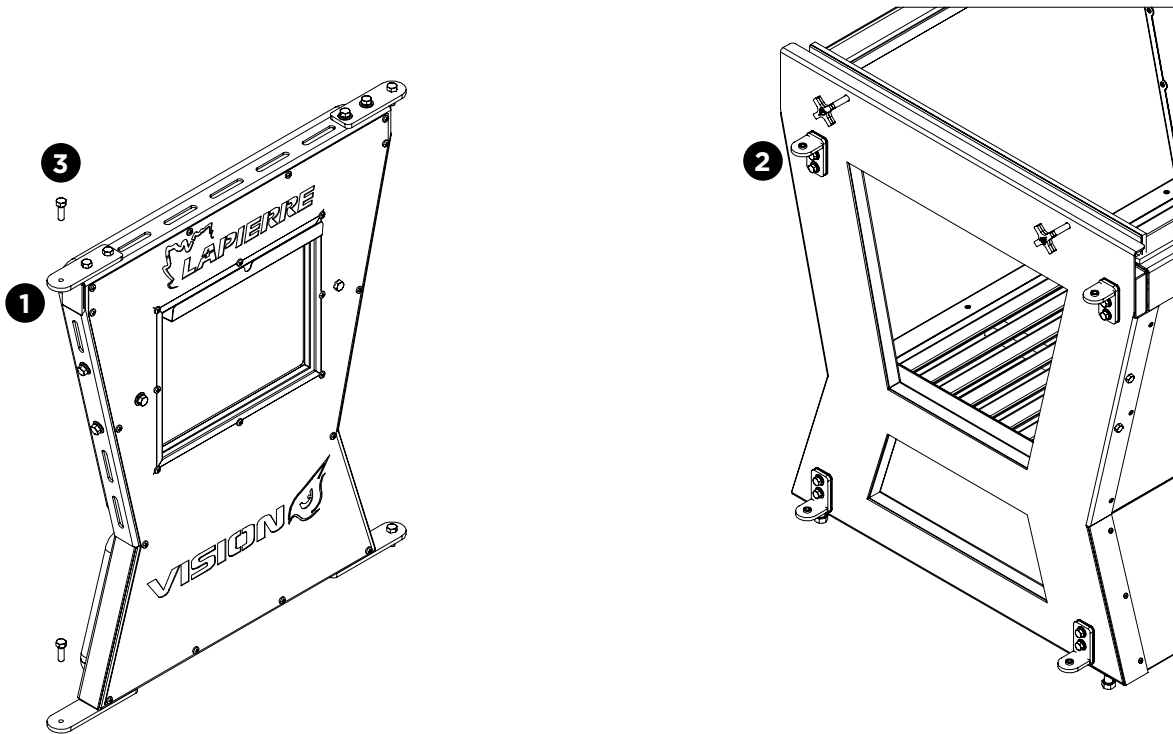

2.1.5.1 Difficulty aligning the mounting holes between the plates and the additional hinges

If, in the previous *Section 2.1.5*, it is difficult or even impossible to align the mounting holes between the plates and the additional hinges, then proceed as follows:

- open the door,
- slightly unscrew the bolts of the additional hinges on the front chassis of the VISION™ (*Section 2.1.2*),
- then, close the door and manually move the additional hinges until alignment is achieved,
 - use one of the bolts (K or W) provided in your conversion kit, if necessary, to facilitate the alignment,
 - it is also possible to slightly move the RETAINING PLATES in their oblong holes,
 - o indeed, the elongated oblong holes allow for a little extra play in terms of positioning,
 - if necessary, unscrew the bolts of the additional hinges further and continue the work until alignment is achieved,
- once the bolts (K or W) are freely inserted into the mounting holes between the plates and the additional hinges, tighten the bolts of the TWO DOOR RETAINING PLATES firmly but not excessively,
- then, mark the position of the additional hinges on the door chassis in some way,
- remove the bolts joining the plates to the additional hinges,
- open the door,

SECTION 2 Steps for converting your VISION™ evaporator to oil (continued)

- tighten the bolts of the additional hinges firmly but not excessively,
 - ensure, by tightening the bolts, that the hinges are IN THE EXACT POSITIONS PREVIOUSLY MARKED on the door chassis,
- close the door,
- position and screw in the bolts joining the plates to the additional hinges firmly but not excessively.

THE PROBLEM PERSISTS | If the problem persists, it is possible to reproduce the previous instructions by slightly unscrewing the hinges and retaining plates THAT ALREADY EXIST on your VISION™ evaporator.

2.2 INSTALLING THE BURNER

It is much easier to carry out certain steps from *Sections 2.2 and 2.3* when the door is open. Consequently, unscrew the two bolts joining the retaining plates to the hinges on only one side of the door and open it. Choose either side as you see fit.

The steps to be followed to replace the ceramic glass of your VISION™ evaporator with the Carlin burner can be found below.

2.2.1 Removing the ceramic glass from the door

- Have a tool for unscrewing the bolts on hand.
- Unscrew and set aside the eight bolts securing the glass frame.
 - ✓ The bolts will be used in the following section.
- Remove the glass frame (1), the two sealing gaskets (2), and the ceramic glass (3).
 - ✗ Keep and put away the frame, the gaskets, and the glass, since they will no longer be used.

ILLUSTRATION 7 | Removing the ceramic glass from the door

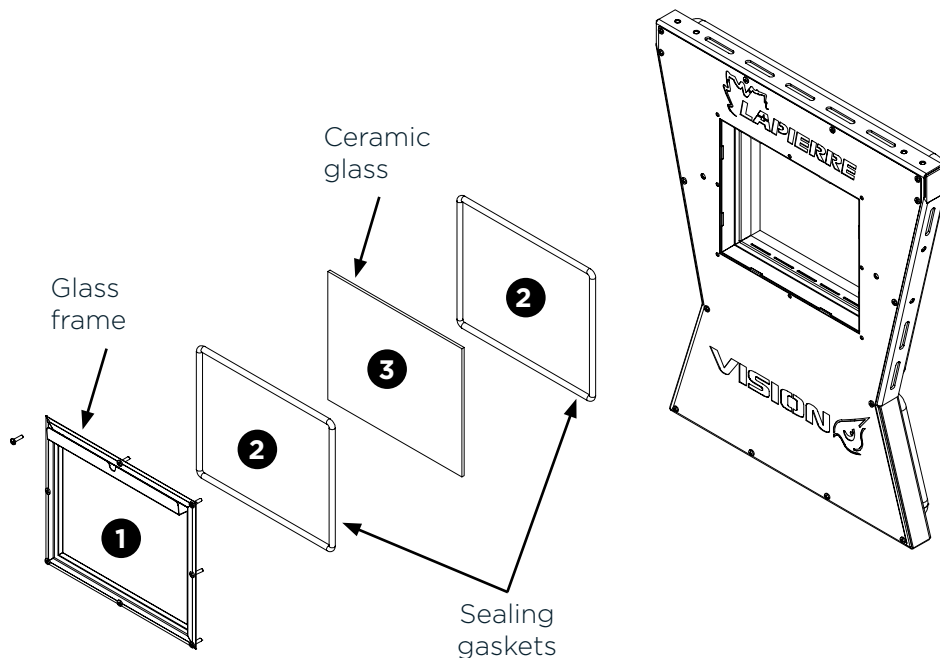

2.2.2 Installing the burner mounting plate in the door

- Retrieve the eight bolts securing the glass frame that you set aside in the previous section.
- Have a tool for screwing the bolts on hand.
- Retrieve the Carlin burner mounting plate (G or R) provided in your conversion kit.
- Secure the plate in place of the ceramic glass using the eight bolts.
 - Tighten each of the bolts firmly but not excessively.

ILLUSTRATION 8 | Installing the burner mounting plate in the door

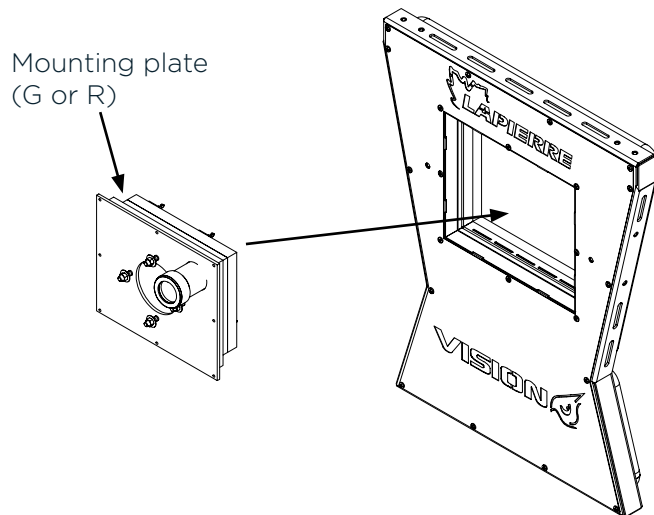

2.2.3 Installing the flange and the sealing gasket on the mounting plate

- Retrieve the flange (1) and the sealing gasket (2) provided with the Carlin burner.
- Have the tool for unscrewing and screwing the nuts (5) of the burner mounting plate on hand.
- Unscrew the four nuts and the eight washers (5) pre-installed on the burner mounting plate.
- Close the evaporator door, if it is open.
- Place the tool, the nuts, the washers, the flange, and the gasket within reach of the door.
- Locate the four oblong holes (3) of the flange (1) and the gasket (2) that you plan to use for the installation, the flange collar (4), and the two pre-installed screws located on this collar (*Illustration 11, No. 8*).
- On the outer face of the mounting plate,
 - first, position the sealing gasket (2), taking care to place four oblong holes (3) into the four pre-attached bolts (5) in the plate,
 - then, position the flange (1) over the gasket in the same way:
 - o taking care to place THE COLLAR (4) TOWARD THE OUTSIDE OF THE PLATE/DOOR,
 - o ensuring that the two screws on the collar (*Illustration 11, No. 8*) are easily accessible for screwing,
 - place the eight washers and the four nuts into the bolts (5) of the plate,
 - o the flat washer must be installed first against the plate, the slotted locking washer second, followed finally by the nut,
 - o tighten the nuts by hand enough so that they stay in place, but not all the way,
 - o then, centre the flange and the gasket in the central opening of the plate (6) and hold them in position,
 - o tighten the nuts to the bolts firmly but not excessively using your tool.

ILLUSTRATION 9 | Installing the flange and the seal in the mounting plate

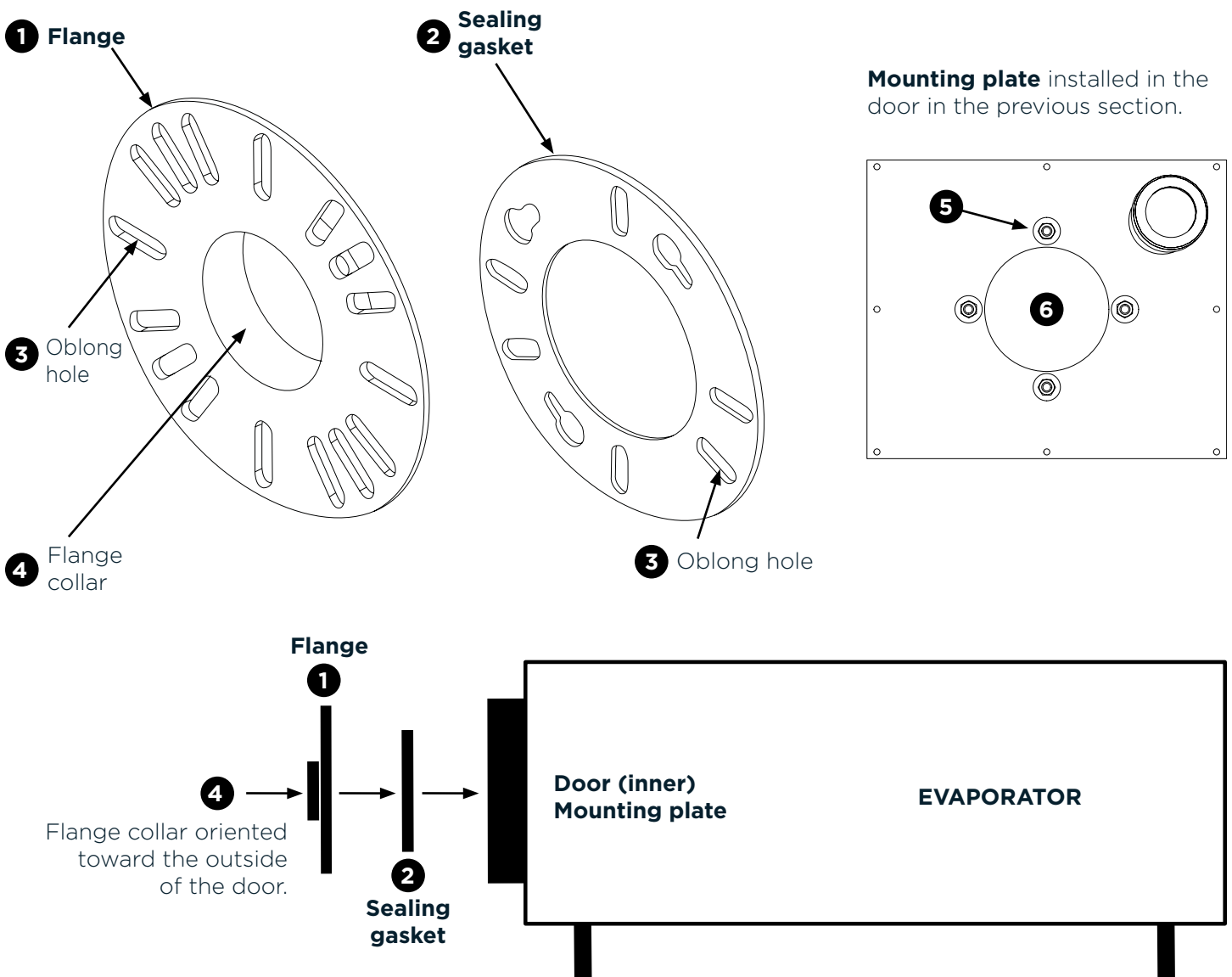

2.2.4 Installing the burner barrel in the mounting plate and the flange

- Retrieve the burner (1) provided by the manufacturer Carlin.
 - Have a tool for unscrewing and screwing the four fixing bolts (2) on hand.
 - Have a flat screwdriver for unscrewing and screwing the two screws (*Illustration 11, No. 8*) on the flange collar on hand.
 - Remove the barrel (3) from the burner.
- You must first unscrew and set aside the four fixing bolts (2).
- ✓ The bolts will be re-used in the following section to re-attach the burner to the barrel.

ILLUSTRATION 10 | Removing the barrel from the burner

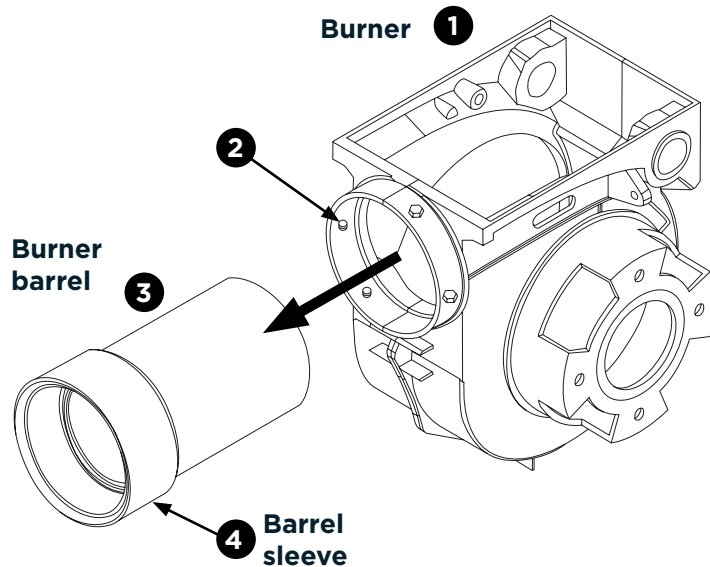

- Open the door of the evaporator.
- From inside the door, insert the barrel into the central opening of the mounting plate.
- The barrel sleeve (*Illustration 10, No. 4 and Illustration 11, No. 5*) must be facing inward, on the evaporator side.
- The edge of the barrel sleeve must be even with the surface of the wool inside the door (6).
- Then, attach the barrel to the flange (7) using the two screws located on the flange collar (8).
 - Ensure that the edge of the sleeve is still even with the surface of the wool in the door (6) before tightening.
- Close the door of the evaporator, join the retaining plates to the additional hinges, but do not tighten the nuts to the bolts immediately, since you may have to open the door again in *Section 2.3*.

ILLUSTRATION 11 | Installing the barrel in the door/mounting plate

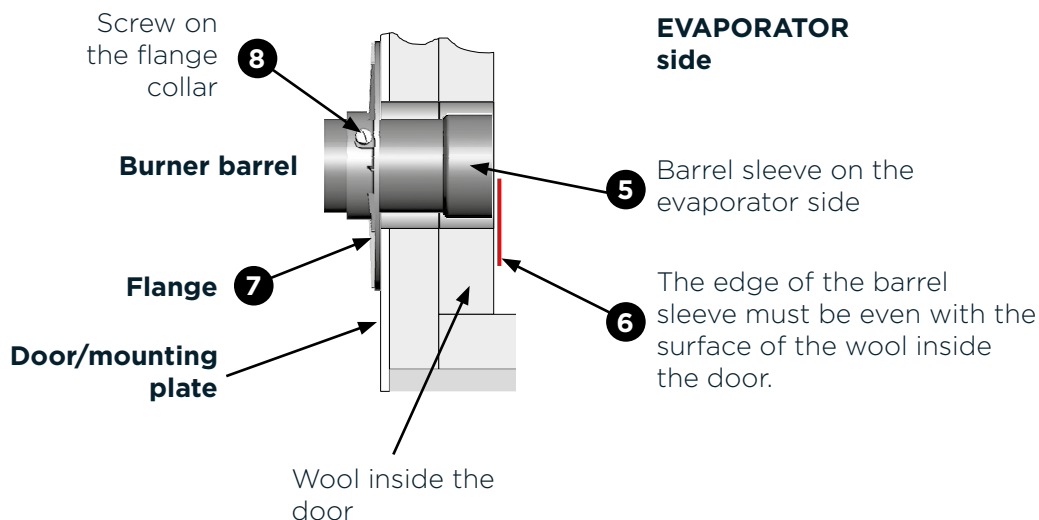

SECTION 2 Steps for converting your VISION™ evaporator to oil (continued)

2.2.5 Installing the burner in the barrel

- Retrieve the burner and the four fixing bolts that you set aside at the start of *Section 2.2.4*.

102CRD burner

- Have a tool for screwing the four fixing bolts on hand.
- First, insert the burner air outlet (1) into the barrel (2), as shown below.
- Use the four bolts to attach the burner to the barrel.
 - Tighten the four bolts firmly but not excessively.

301CRD and 601CRD burner

NOTE | Before installing the burner, locate an unused threaded hole underneath it, toward the front. This is where you will have to attach the eyelet head (3) of the burner support rod.

- Retrieve the support rod (U) (*Illustration 12*) provided in your conversion kit.
 - Ensure that you have on hand the bolt and the washer for the eyelet provided with your support rod.
 - Have on hand the tools for screwing the four fixing bolts and the rod eyelet bolt.
 - Have a wrench or crescent wrench on hand for screwing and unscrewing the nuts on the internal threaded rod (5) which allow you to adjust the burner level.
 - You will also need a level to level the burner.
-
- First, insert the burner air outlet (1) into the barrel (2), as shown below.
 - Use the four bolts to attach the burner to the barrel.
 - Tighten the four bolts firmly but not excessively so that the burner is level.
 - Install the support rod.
 - The support rod has two functions:
 - o stabilizing the burner,
 - o making and keeping the burner level.
- NOTE |** The length of the support rod can be adjusted using its internal threaded rod (5). This feature also allows the final burner level to be adjusted.
- Press the foot of the support rod (4) firmly against the bottom of the chassis in the front of the evaporator.
 - Screw the eyelet (3) of the rod firmly but not excessively into the threaded hole.
 - Check the burner level and adjust it if necessary using the internal threaded rod (5).

ILLUSTRATION 12 | Installing the burner in the barrel

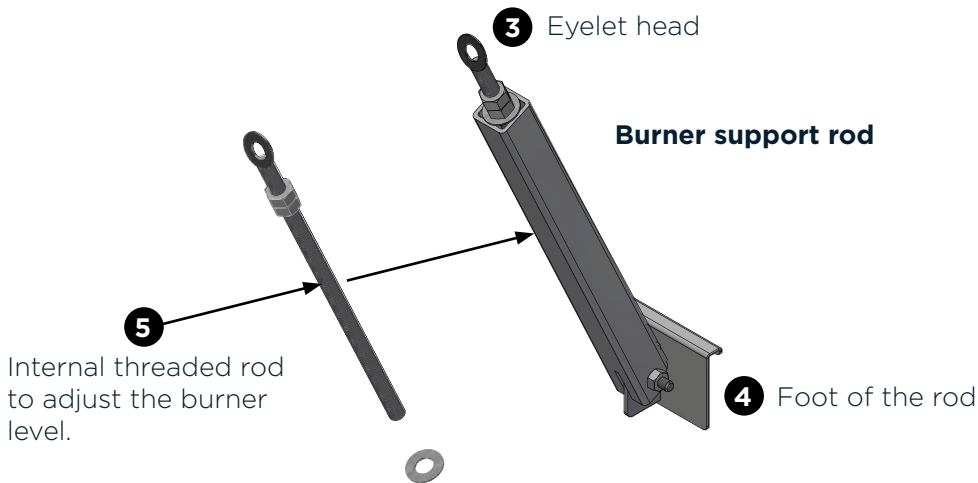
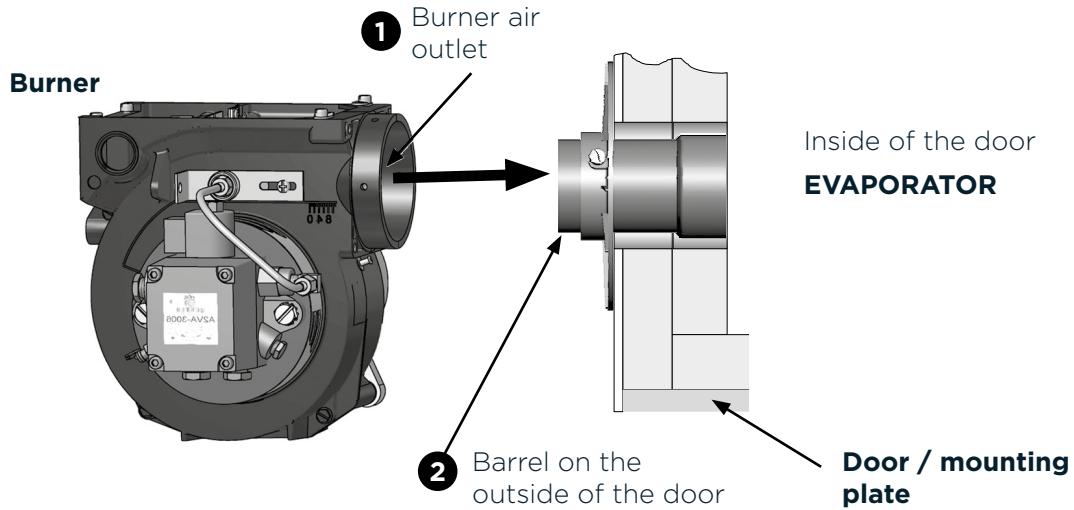

2.3 MODIFYING THE COMBUSTION CHAMBER AND THE THERMAL PROTECTION

The steps to be followed to modify the combustion chamber and the thermal protection of your VISION™ evaporator can be found below.

Retrieve the riser plate from your conversion kit [H (24 in) | S (30 and 36 in)] as well as the insulating wool [I (24 in) | T (30 and 36 in)].

SECTION 2 Steps for converting your VISION™ evaporator to oil (continued)



It is strongly recommended to WEAR A DUST MASK AND GLOVES WHEN preparing and INSTALLING THE INSULATING WOOL in your evaporator.

2.3.1 Installing the riser plate and the insulating wool

Installing the riser plate

- Install the riser plate so that the foot of the plate (1) rests at the bottom of the furnace, at the junction of the end of the bottom grate (2) and the brick riser (3).

ILLUSTRATION 13 | Installing the riser plate and the insulating wool

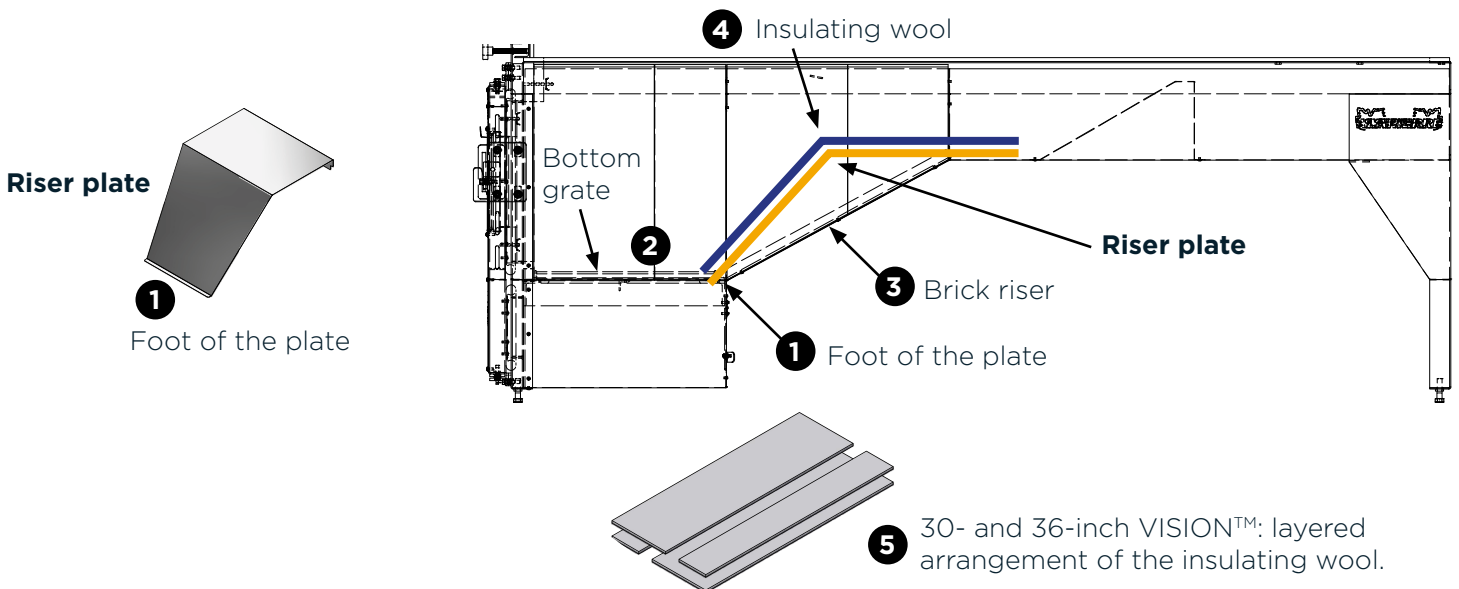

Installing the insulating wool

- Install the insulating wool (4) so as to completely cover the riser plate and ITS NEIGHBOURING PARTS which are exposed in the furnace following the modification made to the combustion chamber.

IMPORTANT | Do not place any wool on the bottom grate of the furnace (2).

- Insulating wool must be installed with a thickness of 2 inches (5.08 cm).

- o 24-inch VISION™: Your conversion kit in *Table 1* includes one piece of insulating wool (I) measuring 2 inches (5.08 cm) thick, so you are compliant.
- o 30- and 36-inch VISION™: Your conversion kit in *Table 2* includes three pieces of insulating wool (T) measuring 1 inch (2.54 cm) thick. One of these pieces must therefore be cut to achieve the layered result of 2 inches (5.08 cm) thick shown in the illustration above (5).

IMPORTANT | Cut the wool so that it completely covers the conversion plate as well as ALL NEIGHBOURING EXPOSED PARTS IN THE FURNANCE that need to be protected from the heat.

- Permanently close the evaporator door.
 - Tighten the two bolts joining the retaining plates to the additional hinges firmly but not excessively.
- Put the pans back in place, if necessary.

2.4 ELECTRICITY AND FUEL OIL CONNECTION OF THE BURNER

The instructions related to the electricity and fuel oil connection of the burner can be found below.

Electricity

- The installation of the power supply to the burner must be entrusted to a qualified electrical contractor. The work must be carried out in accordance with applicable local regulations.

TABLE 5 | Electrical specifications

Burner Controller	102 CRD Model 40200	301 CRD Model 40200	601 CRD Model 40200
Voltage, frequency, and phase	120 V 60 Hz 1-Phase	120 V 60 Hz 1-Phase	120 V 60 Hz 1-Phase
Current	6 A	3.2 A	9 A

The following components, not provided, are required to supply electricity to the burner and allow its startup:

- an electrical plug,
- a power cord,
- an electrical power switch.

Fuel oil

- The installation of the burner's fuel oil supply and return lines must also be entrusted to a qualified contractor specializing in oil-powered burner systems. This installation must be carried out taking into account the instructions contained in the user manual provided by the manufacturer Carlin.

- An oil filter must be installed by the contractor on the fuel line.

- Discuss with your contractor to determine the most appropriate location to install the oil filter on your fuel line.

NOTE | It is recommended to replace the oil filter when starting up the burner at the beginning of each season (*Part 2, Section 2.1*). It is therefore advisable to have a spare oil filter on hand to carry out this maintenance.

Following the installation of the electricity and fuel oil supply, it is possible to start up the burner using the electrical power switch that you just installed.

PART 2

SIMPLIFIED BURNER OPERATION GUIDE

Carlin
Combustion Technology

*Consult the user manual from the manufacturer
Carlin for more information on how the burner works.*





THE PRESENCE OF BLACK SMOKE coming out of the chimney OR SOOT UNDER THE evaporator PANS REQUIRES THE ASSISTANCE OF A QUALIFIED TECHNICIAN to carry out an adjustment of the burner and a carbon monoxide test.

1.1 FIRST LIFETIME STARTUP OF THE BURNER

Once your evaporator is converted to oil and ready for use, contact us, and a Lapierre Equipment technician will come to your location in order to carry out the first startup of your burner/evaporator.

During this visit, the Lapierre technician will, among others, perform the following tasks:

- an oil pressure check,
- an ignition test,
- a test run,
- a combustion test,
- a carbon monoxide test,
- sharing information on the functioning of the burner/controller in relation to the evaporator.

1.2 BURNER OPERATION SEQUENCE

The operation sequence for the Carlin burner on your VISION™ evaporator can be found below.

Once you press the switch (1), the system turns on and the operation sequence is as follows:

Pre-purge cycle

1. The GREEN LED indicator light on the controller illuminates and remains illuminated throughout the cycle.
2. The fan runs for 2 minutes at the start of the cycle to remove the smoke and oil vapour that has accumulated in the combustion chamber.
3. It is normal for ignition sparks to be generated during this cycle.
4. At the end of the cycle, the oil is admitted to the burner.

Ignition and burner startup

5. The burner ignites, the GREEN LED indicator light on the controller turns off, and the YELLOW indicator illuminates, which confirms that the burner is working.
 - If the burner does not ignite, refer to *Section 4.1*.
 - If the RED LED indicator light (Error) illuminates, refer to *Section 4.2*.
 - If the YELLOW and RED LED indicator lights (Error) illuminate simultaneously, refer to *Section 4.3*.

Burner shutdown

6. Simply press the switch (1) to turn the burner off and stop the evaporation operation.

TABLE 6 | Carlin burner statuses and LED indicator lights

Status	LED indicator light	Notes
Pre-purge cycle	Green	<ul style="list-style-type: none"> o The fan runs for two minutes at the start. o Ignition sparks are generated. o At the end of the cycle, oil is admitted to the burner.
Ignition and burner startup	Yellow	The burner ignites and runs.
ERROR MODE / Reset	Red	Press the switch for 1 to 3 seconds. <i>Refer to Section 4.2 for more information.</i>
ERROR MODE / Technician	Yellow + red simultaneously	Request assistance from a technician. <i>Refer to Section 4.3 for more information.</i>

ILLUSTRATION 14 | Carlin burner controller model 40200*

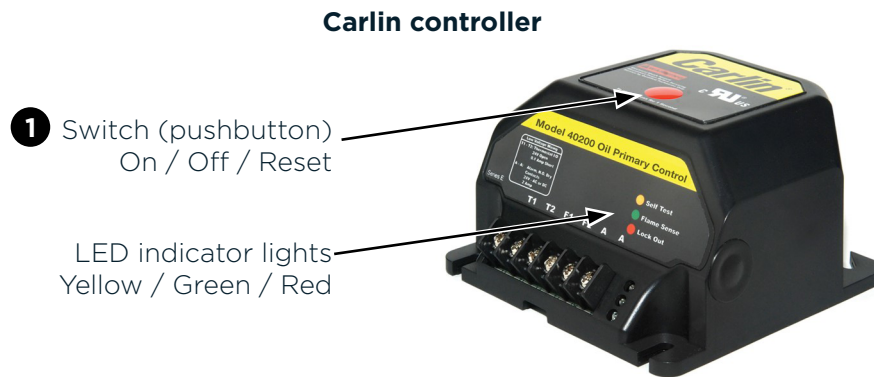

** It is recommended to have a spare controller on hand.*

NOTE | The Carlin burner and controller are equipment provided by a third party - *Carlin Combustion Technology*. We encourage you to consult the user manuals for this equipment for more information on their technical characteristics, operation, and maintenance. If questions persist despite consulting these documents, please contact a qualified regional contractor specializing in oil-powered burner systems or specialists from the manufacturer Carlin directly.

2.1 BURNER STARTUP AT THE BEGINNING OF EACH SEASON

Here is a list of the tasks that you have to perform at the start of each season:

- check the fuel level in your fuel oil tank,
- replace the oil filter on the fuel line,
- open the fuel oil supply,
- open the power supply to the burner,
- conduct a visual inspection of the burner and its fuel oil supply and return lines,
- conduct an ignition test,
- conduct a test run,
- if it is possible for you to do so:
 - check the oil pressure,
 - conduct a combustion test,
 - conduct a carbon monoxide test.



THE PRESENCE OF BLACK SMOKE coming out of the chimney OR SOOT UNDER THE evaporator PANS REQUIRES THE ASSISTANCE OF A QUALIFIED TECHNICIAN to carry out an adjustment of the burner and a carbon monoxide test.

2.2 BURNER SHUTDOWN AT THE END OF EACH SEASON

Here is a list of the tasks that you have to perform at the end of each season:

- cut off the power supply to the burner to avoid possible damage to the controller,
- cut off the fuel oil supply.

2.3 THREE-YEAR MAINTENANCE: NOZZLE, BURNER, AND CARBON MONOXIDE

It is strongly recommended to perform the following tasks CAREFULLY EVERY THREE YEARS.

- Replace the nozzle.*
- Check the overall operation of the burner.
- Conduct a carbon monoxide test.

* *The nozzle is available from your LAPIERRE EQUIPMENT distributor.*

* *The assistance of a qualified technician specializing in oil-powered burner systems or a specialist from the manufacturer Carlin is strongly recommended to replace the nozzle of your burner.*

SECTION 3 PARTS AND CONSUMABLES

Parts for your Carlin burner or any other equipment manufactured at LAPIERRE EQUIPMENT are available at our main plant in Saint-Ludger, Quebec, Canada and our service centers in Waterloo, Quebec, Canada and Swanton, Vermont, USA. However, do not hesitate to contact us or visit our website to locate the distributor nearest you.

HEAD OFFICE and MAIN PLANT

Lapierre Equipment Inc.
99 Rue de l'Escale
Saint-Ludger (QC)
GOM 1W0

Toll Free 1 833 548.5454
Telephone 819 548.5454
Fax 819 548.5460
info@elapierre.com

SERVICE CENTER and PRODUCTION PLANT

Lapierre-Waterloo-Small Inc.
201 Rue Western
Waterloo (QC)
JOE 2N0

Toll Free 1 833 548.5454
Telephone 450 539.3663
Fax 450 539.2660
info.lws@elapierre.com

SERVICE and DISTRIBUTION CENTER

Lapierre USA Swanton
102 Airport Access Road
Swanton, VT
05488

Telephone 802 868-2328
Fax 802 868-9281
info.usa@elapierre.com

www.elapierre.com

4.1 THE BURNER DOES NOT IGNITE FOLLOWING THE PRE-PURGE CYCLE

In relation to sequence No. 5 from *Section 1.2: Burner operation sequence*.

“If the burner does not ignite.”

- If the burner fails to ignite following the pre-purge cycle, the system repeats the loop from sequence No. 1 of the pre-purge cycle.
- If, on this second attempt, the burner still fails to ignite, the fan stops and the RED LED indicator light illuminates, which indicates that the burner is in error mode.
 - Proceed to point 4.2 below.

4.2 THE RED LED INDICATOR LIGHT ILLUMINATES: ERROR / Reset

If the RED LED indicator light illuminates, this indicates that the burner is in error mode.

In relation to sequence No. 5 from *Section 1.2: Burner operation sequence*.

“If the RED LED indicator light (Error) illuminates.”

- A reset may be the solution.
- To reset the system, press the switch (*Illustration 14, No. 1*) for 1 to 3 seconds. Stop pressing the button once the system turns on.
- The system then starts at sequence No. 1 of the pre-purge cycle (*Section 1.2*).
- If the system does not start after 3 seconds, release the switch and try again.
 - If the burner still fails to turn on and the YELLOW and RED LED indicator lights illuminate simultaneously, proceed to point 4.3 below.

4.3 THE YELLOW AND RED LED INDICATOR LIGHTS ILLUMINATE SIMULTANEOUSLY: ERROR / Technician

If the YELLOW and RED LED indicator lights illuminate simultaneously, this indicates that the burner is in error mode.

In relation to sequence No. 5 from *Section 1.2: Burner operation sequence*.

“If the YELLOW and RED LED indicator lights (Error) illuminate simultaneously.”

- If, following the second reset attempt (*Section 4.2 above*), the burner still fails to ignite*, the YELLOW and RED LED indicator lights illuminate simultaneously, which indicates that the burner is still in error mode. In this case, it is necessary to request assistance from a qualified technician.

* *One startup attempt + two reset attempts = 3 ignition and startup attempts.*

APPENDIX A USER MANUAL FOR CARLIN CONTROLLER MODEL 40200

In the following pages, you can find the *User Manual for Carlin Controller Model 40200*.

You will find several useful pieces of information there on:

- installation and cabling,
- **startup and operation (LED indicator lights),**
- troubleshooting.

If necessary, download this same manual on the manufacturer's website:



Carlin controller 40200

[Product page](#)

[User manual for the product](#)



Carlin[®]
Combustion Technology

**Model 40200/42230
CAD Cell Oil Primary Control
Data Sheet**



LAPIERRE EQUIPMENT ASSUMES NO LIABILITY FOR THE CONTENT OF THE USER MANUAL FOR THE CARLIN CONTROLLER, model 40200, included in the following pages.



Carlin[®]
Combustion Technology

**Model 40200/42230
CAD Cell Oil Primary Control
Data Sheet**

- **Oil Pump Bleed Assist**
Up to 1 min.
- **Recycle on Flame Failure**
- **Serviceman Reset Protection**
Latch-up after 3 consecutive lockouts
- **Diagnostic LEDs**
Status, lockout, flame
- **15-second, 30-second TFI**
- **Increased Flame Accuracy**
- **Thermostat/Aquastat Compatible**
- **Improved SMC Technology**
Zero bleed voltage during standby
- **Works Well with Generators**
Insensitive to frequency changes
- **Flame Stabilize**

Power input (from limit circuit)	120 VAC, 60 HZ, 10 VA
Motor load	10 FLA / 60 LRA
Ignitor load	120 VAC, 60 HZ, 500 VA
Operating temperature limits	+32°F to +140°F

Storage temperature limits	-40°F to +185°F
Thermostat anticipator current	0.1 A, AC
CAD cell resistance (with flame)	R < 1500 OHMS
Agencies	UL recognized (US & Canada)

Installing and Wiring

⚠ WARNING 40200 and 42230 controls must be installed and serviced only by a qualified service technician.

1. Always disconnect power source before wiring to avoid electrical shock or damage to the control. All wiring must comply with applicable codes and ordinances.
2. Thermostat terminals (T-T) provide a current source. Never apply external power to these terminals under any circumstances.

Mounting

- The control may be mounted on a 4" x 4" junction box in any convenient location on the burner, furnace or wall. The location must not exceed the ambient temperature limit, 140°F.

Wiring

- Wiring must comply with local and national electrical codes, and with the wiring diagram.
- Individual or bundled neutrals may be attached to any L2 terminal.

Field checks

1. **Safety timing (TFI) test** – Remove one cad cell wire (F-F). Start burner. The control should lockout within the TFI time limit. Replace cad cell wire.
2. **Flame failure test** – Start burner. After flame is established (after TFI period), close the oil supply hand valve. This will cause a flame failure sequence as described in the Startup & Operation section of this Data sheet. The control should recycle (restart after 65 seconds).
3. If control does not operate as described, check the wiring.



SEE WIRING DIAGRAM ON NEXT PAGE

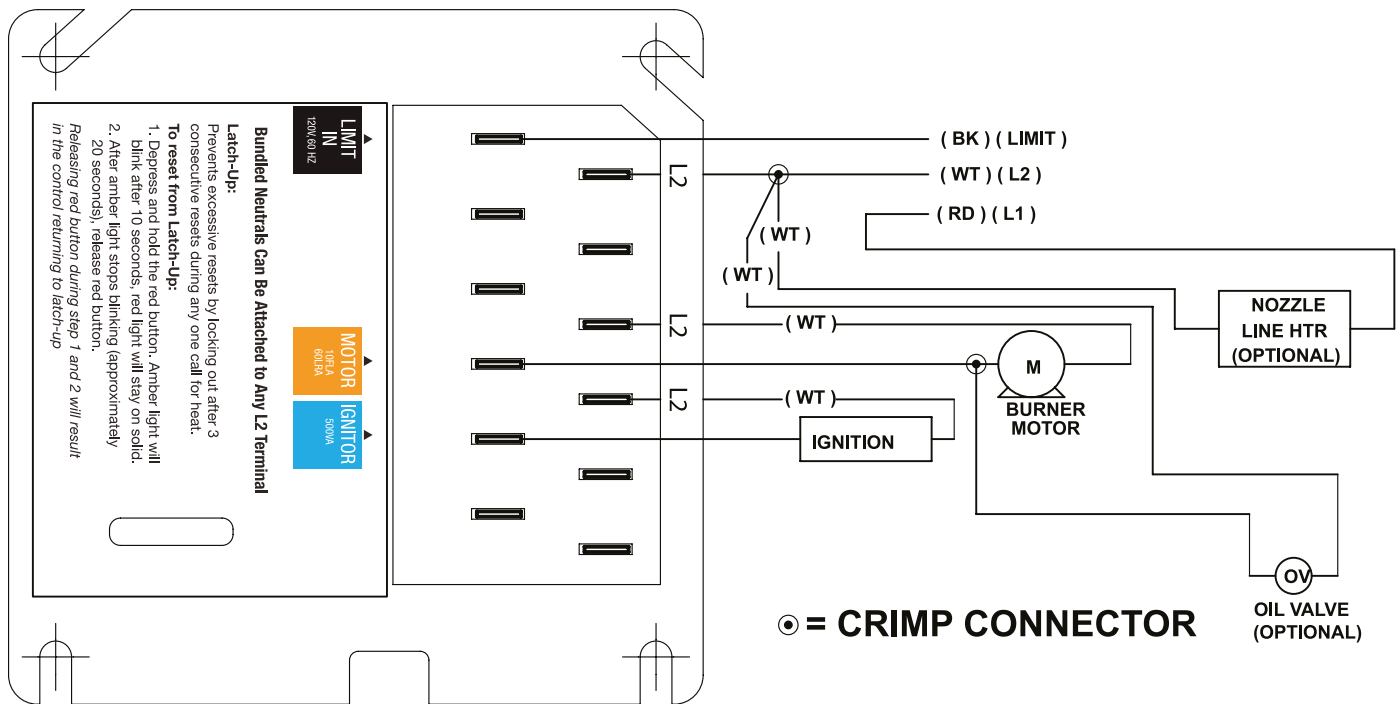







Wiring

















































Start-up & Operation

WARNING Do not start the burner if the combustion chamber contains oil or oil vapor.

NOTICE Per UL requirements, the control will not turn on if the CAD cell senses flame during the self-test. If the CAD cell sees light (flame) at the beginning of a cycle, the control will remain in self-test mode until the CAD cell no longer senses light (flame). The amber LED will blink momentarily  every 3 to 4 seconds and green LED will be on  or flashing .

Model 40200 & 42230 Diagnostic LEDs		
 – Amber OFF	 – Amber ON	 – Amber FLASHING
 – Green OFF	 – Green ON	 – Green FLASHING
 – Red OFF	 – Red ON	 – Red FLASHING

-    **Power ON** Open all manual oil line valves. Close the line switch.
-    **Self-test 1** The control performs a “boot-up” test to verify internal operation each time power is applied to the black wire. The amber LED turns on and the test continues for about 5 seconds. If the test fails, the control turns the amber LED off and repeats this test sequence until successful.
-    **Stand-by** (No call for heat) If Self-test 1 is successful, amber LED turns off and control waits for heat call.
-    **Call for heat** Set thermostat and limit to call for heat. Thermostat circuit must be closed and power coming to black wire from limit circuit.
- Self-test 2** If a failure occurs in this self-check, the control won’t start and the amber LED blinks 1 second on, 4 seconds off, until serviced or the problem clears. These failures include CAD cell seeing light, internal fault, or line voltage <90V. See service section.
-    **Burner on** After the self-test, amber LED turns off. The ignitor starts, followed 2 seconds later by the motor.
-    **Pump Prime** To enter pump prime: 1. Start a CFH cycle. During Pre-Ignition, press Reset. Motor turns off (10 seconds), then release the button. When motor turns back on, within 5 seconds, press the Reset button until the amber LED starts to flash. You are in Pump Prime, release Reset button.
Optional Pump Prime notes: 1) If lost, press Reset for 1 second and release, then if the control is not in Pump Prime, restart the sequence. 2) If Reset is released before end of first 10 seconds, the control returns to Standby and restarts another CFH cycle. 3) If reset is not pressed the second time, a normal CFH cycle will continue. 4) If motor and ignitor are on and amber LED is flashing, the control is in Pump Prime. 5) Pump Prime will exit standby if flame is detected, or 60 seconds has elapsed, or loss of TT or Limit, or Reset button is pressed.
-    **TFI** The CAD cell must sense flame within the TFI time limit (trial for ignition). Insufficient flame puts control into lockout.
-    **Run** The burner continues firing during call for heat if the CAD cell is sensing flame. Only the green LED is on during normal running.
-    **Lockout** If CAD cell does not sense flame within the TFI time limit after the burner starts, lockout occurs. The control turns the red LED on constant, and closes the alarm contact.
To Reset Push in and hold reset button for 2 seconds, then release.
-    **Latch-up** If the control locks out 3 times during a single call for heat, latch-up occurs. The control turns on both the amber and red LEDs constant. You must use the special procedure below to reset the control after latch-up.
WARNING **Reset after latch-up:** Only a qualified service technician should attempt to reset the control after latchup. The problem that caused the repeated burner lockouts must be corrected before returning the burner to normal operation.
-    **To Reset** Push in and hold the reset button for 10 seconds. The amber LED will begin to flash.
   After the LED begins flashing, continue holding the reset button for 20 seconds. The LEDs will turn off. Release the reset button and the control will restart (releasing the button before the LEDs turn off will cause the control to remain in latch-up).
NOTICE The 40200 & 42230 controls will retain lockout or latchup if power is interrupted.
-    **Flame Failure** If the CAD cell loses flame signal during operation (after the TFI), the red LED flashes. Recycle: Control waits for 65 seconds (with red LED flashing), then begins again at Self-test 2. Red LED goes off .
-    **NOTICE** If the green LED is blinking during a run, the flame is weak or unstable which may cause recycle.
-    **Stand-by** Control remains in stand-by mode until limit circuit sends power to the black wire and thermostat circuit closes (call for heat).

Service & Troubleshooting

Burner (control) will not come on

ⓐ ⓑ ⓓ No power to control

- Check limit circuit to the control (at least 102 VAC).
- Check all electrical connections.

ⓐ ⓑ ⓓ Control is in lockout

- Red LED will be on. Press the reset button for 2 seconds.

ⓐ ⓑ ⓓ CAD cell seeing light

- Green LED on, and amber LED blinking 1 second on, 4 seconds off. Remove one yellow lead from FF terminals, and the flame test plug. If the amber LED remains flashing, the control is defective.

If the amber LED goes OFF, the control is OK, and;

- light is leaking into the burner housing, or
- CAD cell is defective, or
- there is a problem with the CAD cell wiring or holder.
- If appliance was recently shut down, CAD cell may see residual hot spots in chamber.

To troubleshoot:

- Attach multimeter to monitor CAD cell resistance. Dark resistance should be over 50K ohms, and room light resistance (control flipped open) should be at most 10K ohms. Replace cell if necessary, or reinstall and close the burner housing.
- Check for stray light by measuring the CAD cell resistance looking into the inactive combustion chamber. It should read at least 50 kohms.

ⓐ ⓑ ⓓ Other no start problems

If the CAD cell is OK, and the amber LED still blinks 1 second on, 4 seconds off, the other possible failures include:

- Line voltage <90 VAC (amber LED flashes uniquely, 1 second on, 1/2 second off, 1 second on, 3 seconds off, then repeats). *Check line voltage.*
- Internal fault. CAD cell and line voltage OK. The issue may be an internal fault. *Replace the control.*

Repeated flame failures (ⓐ ⓑ ⓓ flashing red LED)

Check for:

- CAD cell is defective. *Replace.*
- Air leaking into oil line causing flame out. *Check oil line connections and filter gasket.*
- Defective nozzle causing flame to be erratic. *Change nozzle.*
- Excessive airflow or draft causing flame to leave burner head. *Check for proper air band setting and draft.*
- Excessive back pressure causing flame to be erratic. *Check appliance and flue for sooting/plugging.*

Control locks out at end of TFI (ⓐ ⓑ ⓓ red LED on)

Check for:

- No oil to burner. *Check oil supply, filters, lines.*
- Shorted electrodes. *Inspect for cracked porcelain and replace as needed.*
- Poor spark. Check electrode spacing and condition per burner manual. *Replace or realign if necessary.*
- Nozzle clogged. *Replace nozzle.*
- Airflow too high. *Check air band setting.*
- Ignitor module defective. *Replace if no spark.*
- CAD cell defective
- Oil valve (if used) stuck in closed position.
- Check wiring connections.

ⓐ ⓑ ⓓ Blinking Green LED

- Weak or unstable flame.
- Check ohms.
- Check CO₂ level.

NOTICE

FROZEN PIPES/WATER DAMAGE: This is not a freeze protection device. Suitable freeze protection monitoring or other precautions are recommended to protect against ruptured pipes/water damage caused by fuel outage, safety related fault conditions, or equipment failures.



We sincerely appreciate your trust.

Thank you!



Printed in Canada • LAPIERRE EQUIPMENT © All rights reserved - 2026

99 Rue de l'Escale, Saint-Ludger (QC) Canada G0M 1W0
819 548.5454 | 1 833 548.5454 | info@elapierre.com | www.elapierre.com